

Rogowski AC Current Probe RCP Series

User Manual

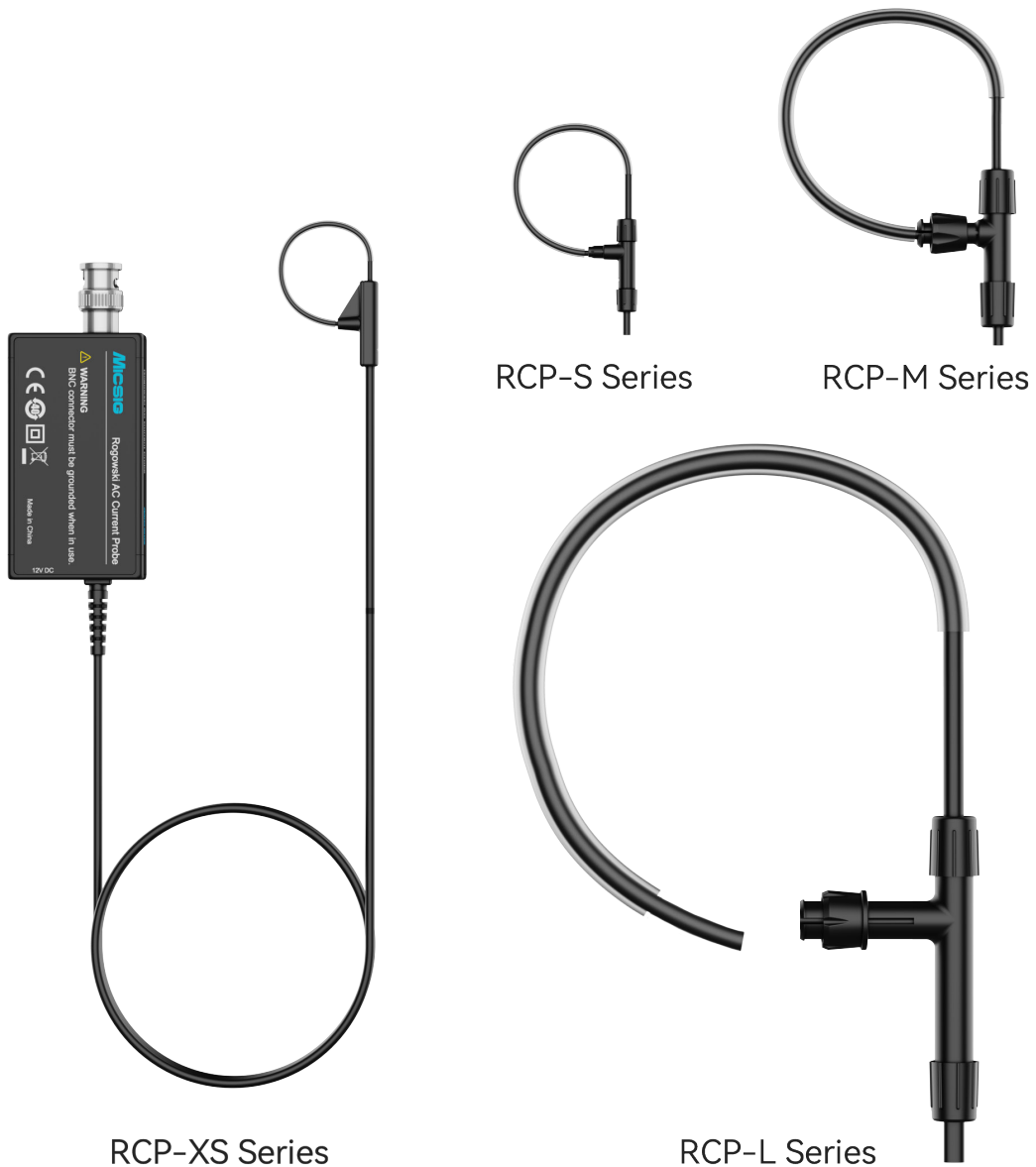

Disclaimer

All information provided in this document is delivered “as is.” Future updates may be obtained by visiting the Micsig official website (www.micsig.com).

To the fullest extent permitted by applicable law, Micsig makes no express or implied warranties with respect to this manual or any of the information contained herein, including but not limited to implied warranties of merchantability or fitness for a particular purpose. Micsig shall not be liable for any errors, incidental or consequential damages arising from the provision, use or application of this document or the information it contains.

If a separate written agreement between Micsig and the user includes warranty terms relating to the contents of this document, and such terms conflict with the provisions herein, the warranty terms in the separate agreement shall prevail.

Warranty

The current probe body is guaranteed for 1 year. During the warranty period of the product, the company will be responsible for providing free maintenance for any faults caused by the quality of the product itself under normal use and has not been dismantled or repaired.

The warranty is invalid in the following cases, but maintenance services are provided, labor costs are waived, and only spare parts are charged:

- a. Damage to accessories due to improper use, maintenance, or storage.
- b. Damage caused by force majeure factors, such as natural disasters.

In the following cases, the company will refuse to provide maintenance services or provide maintenance services for a fee:

- a. Unable to provide product packaging or anti-counterfeiting labels on product packaging.
- b. The content of the anti-counterfeiting label has been altered, or is blurred and unrecognizable.
- c. It has been dismantled by unauthorized personnel by Micsig (eg: changing wires, dismantling internal components).
- d. There is no sales voucher or the content of the sales voucher does not match the product.

Content

General Safety Summary	2
Maintenance Safety	3
Compliance Information.....	4
Safety Compliance	4
Environmental Considerations	5
Certification complies with the standards	5
Main Functions.....	6
Probe Structure	6
Operating Instructions	7
Obtain Optimal Measurement	8
Technical Specifications	9
Physical Characteristics	9
Electrical Characteristics	10
Environmental Characteristics	11
Precautions	12
Maintenance.....	13
Troubleshooting	13
Cleaning	14

General Safety Summary

Please read the following safety precautions carefully to avoid personal injury and prevent damage to this product or any product connected to this product.

To avoid possible danger, be sure to use this product as prescribed.

Only qualified personnel should perform repair procedures.

Avoid fire or personal injury

Connect and disconnect devices properly.

- * Do not plug or unplug probes or test leads while they are connected to a voltage source.
- * Power off the circuit under test before connecting or disconnecting the current probe.
- * Before connecting the probe to the circuit under test, please connect the probe output to the measuring instrument.
- * Before connecting the probe input, please connect the probe reference lead to the circuit under test.
- * Before disconnecting the probe from the measuring instrument, please disconnect the probe input end and the probe reference lead from the circuit under test.

Observe all terminal ratings. To avoid fire or electric shock, observe all product ratings and markings. Before making connections to the product, please consult the product user manual for details on ratings. Do not connect the current probe to any wire with a voltage exceeding its rating.

Do not disassemble the instrument. Do not use the product for measurements with covers or panels open.

Do not operate the product when it is suspected that the product is malfunctioning.

Keep away from exposed circuits. Do not touch exposed wiring and components while the power is on.

Do not operate in wet environments.

Do not operate in flammable and explosive environments.

Please keep the product surface clean and dry.

Terms in this manual

 **WARNING:** A "WARNING" statement identifies conditions or actions that could result in personal injury or life-threatening conditions.

 **CAUTION:** A "CAUTION" statement identifies conditions or actions that could cause damage to this product or other property.

Maintenance Safety

Only qualified service personnel with relevant qualifications should perform service operations. Please read this "Maintenance Safety Summary" and "General Safety Summary" before performing any repair operations.

Do Not Serve Alone: Do not make internal repairs or adjustments to this product unless someone else is on site to provide first aid and resuscitation.

Disconnect Power: To avoid electrical shock, disconnect power to the instrument before disconnecting the main power cord.

Pay attention when repairing with electricity: Hazardous voltages or currents may be present in this product. Disconnect power and test leads before removing protective panels, soldering, or replacing components.

To avoid electric shock, do not touch exposed connectors.

Compliance Information

This section lists the EMC (Electromagnetic Compatibility), safety and environmental standards to which the instrument complies.

Safety Compliance

Equipment Type

Test and Measurement Equipment.

Pollution Degree

The micro-environmental pollution levels used to determine clearances or creepage distances can be classified into 4 levels.

- * Pollution degree 1: no pollution or only dry non-conductive pollution.
- * Pollution degree 2: In general, there is only non-conductive pollution, and occasional temporary conduction caused by condensation occurs. typical office/home environment. Temporary condensation occurs only when the product is not in use.
- * Pollution degree 3: There is conductive pollution, or dry non-conductive pollution becomes conductive due to expected condensation.
- * Pollution degree 4: Causes persistent conductive pollution, such as pollution caused by conductive dust or rain and snow.

Pollution Degree

Pollution Degree 2

Overvoltage Class Description

The overvoltage level is divided according to the IEC60664 standard, which is divided into four levels: CAT I, CAT II, CAT III, and CAT IV.

- * CAT I is a low-voltage low-energy class with protective devices, generally referring to the internal voltage of electronic equipment.
- * CAT II is a low-voltage high-energy level, branched from the main power supply circuit, and the 220V voltage of the home lighting circuit belongs to this category.
- * CAT III refers to the high voltage and high energy level, refers to the fixed installation of the main power supply circuit, generally refers to 380V three-phase voltage.
- * CAT IV refers to three-phase lines at utility power connections, any outdoor conductors.

Overvoltage Category

CAT II

Environmental Considerations

This section provides information about the environmental impact of the product.

Product End-of-Life Handling

Observe the following guidelines when recycling an instrument or component:

Equipment Recycling: Production of this equipment requires the extraction and use of natural resources. The equipment may contain substances that could be harmful to the environment or human health if improperly handled at the product's end of life. In order to avoid release of such substances into the environment and to reduce the use of natural resources, we encourage you to recycle this product in an appropriate system that will ensure that most of the materials are reused or recycled appropriately.



This symbol indicates that this product complies with the relevant requirements of European Union Directives 2002/96/EC and 2006/66/EC on Waste Electronic and Electrical Equipment (WEEE) and Batteries.

Certification complies with the standards

EC Conformity Declaration - Low Voltage:

Low Voltage Directive 2014/35/EU

EN 61010-1:2010 /A1:2019

Safety requirements of electrical equipment for measurement, control, and laboratory use.

EN 61010-2-032:2023

Specific provisions for hand-held current clamps for electrical measurement and test equipment.

Main Functions

The Micsig RCP series Rogowski current probe measures AC currents up to 12000 Apk, offers a maximum bandwidth of 30MHz. With nearly zero insertion impedance, the probes minimize interference to the circuit under test. The coil features extremely high voltage resistance (up to 10 kVpk). Customization is available for coil cross-sectional diameter, perimeter, wire length, voltage withstand capacity, and operating temperature, enabling adaptation to complex application scenarios.

It features a standard BNC interface for use with any oscilloscope. Its compact, flexible design easily solves the hard-to-reach part issue, and the coil diameter supports customization to meet more test requirements.

Probe Structure

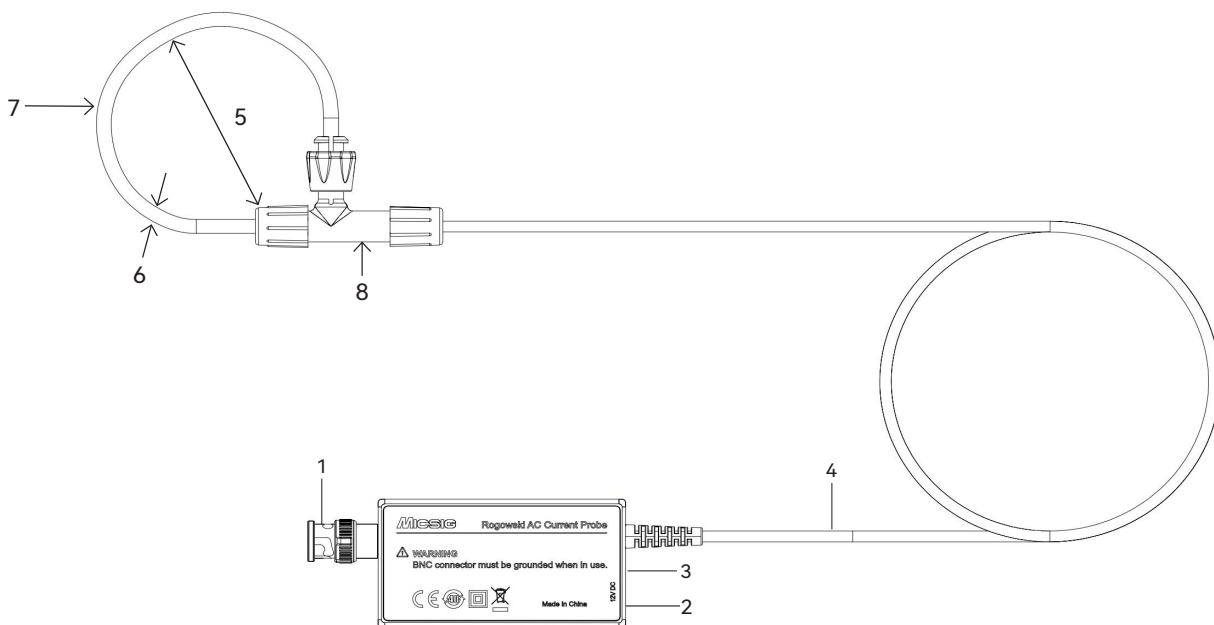

The image is shown using the standard RCP-M model.

- 1) Output: Standard BNC, compatible with all BNC oscilloscopes.
- 2) Power supply: DC 12V, adapter
- 3) Power indicator: Turn Green after powered on.
- 4) Cable length: 1.5m, from integrator to coil, customizable.
- 5) Rogowski coil inner diameter (customizable).
- 6) Rogowski coil cross-section diameter (customizable).
- 7) Rogowski coil length: customizable.
- 8) Current direction.

Operating Instructions

Connecting to an oscilloscope

1. Connect the probe BNC cable to the channel interface of the oscilloscope.
2. Power the probe control module with the standard 12V power adapter provided with the probe.

⚠ CAUTION: Must use the adapter provided with the probe for power supply, DO NOT use USB port on the oscilloscope.

Operation steps

1. Connect the probe to any channel of the oscilloscope.
2. Set the oscilloscope input impedance to 1 MΩ.
3. Power the current probe using the supplied adapter. After power-on, the power indicator will light green.
4. Connect the current probe to the device under test (DUT) to begin measurement. Make sure the coil plug is fully inserted.
5. Adjust the oscilloscope settings or use the oscilloscope's auto-setup function to display a stable waveform.

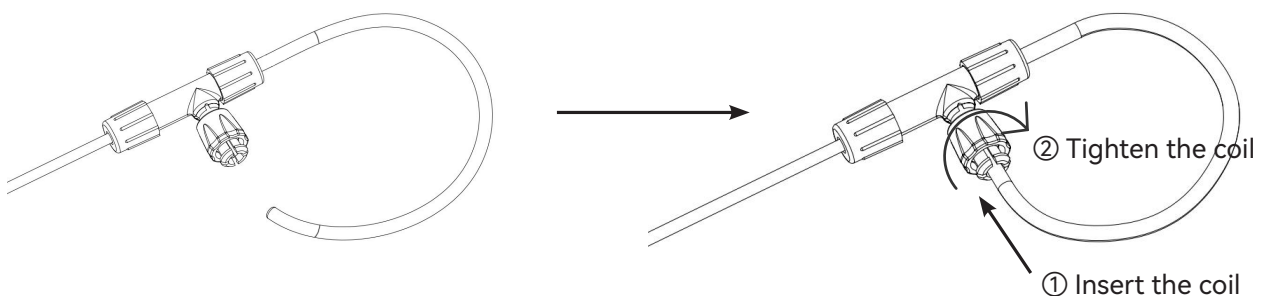

The image is shown using the standard RCP-M model.

When noticeable resistance is felt at the free end of the coil, the coil is fully inserted.

⚠ WARNING: The probe does not protect against electric shock when connecting to or removing it from hazardous live conductors

⚠ WARNING: The probe can only be installed or removed when the circuit is power off.

⚠ WARNING: Do not drop the probe or subject it to strong shocks, as this may result in damage to the probe.

⚠ WARNING: Do not connect the current probe to any conductor carrying current exceeding the probe's rated value.

Precautions

- * Visually inspect the insulation around the Rogowski coil before use and do not use it if any damage is found.
- * Avoid sharp bends or overly tight loops when winding the flexible coil around a conductor to prevent damage.
- * Do not use the coil in environments exceeding its rated voltage.
- * The detachable silicone sleeve provides additional mechanical protection.
- * Do not touch the measured conductor or the probe sensor head during measurement.
- * Use the Rogowski coil only with oscilloscopes or monitoring devices whose BNC input is properly grounded.

Obtain Optimal Measurement

⚠ Caution: The probe head is a precision part. Do not drop the probe or physically shock it, twist it, or drastically alter its surroundings. Do not insert wires larger than jaw diameter into the probe grip, as this may damage the probe.

- ※ to ensure accuracy, the wire being measured should be positioned as much as possible between X and Y in the right diagram, where X is the center of coil and Y is the midpoint of the coil length.
- ※ try to stay away from strong magnetic field interference sources as much as possible to avoid measurement errors.
- ※ the coil can be placed around the wire being measured to measure the interference signals in the surrounding area, to determine whether there is strong interference nearby.

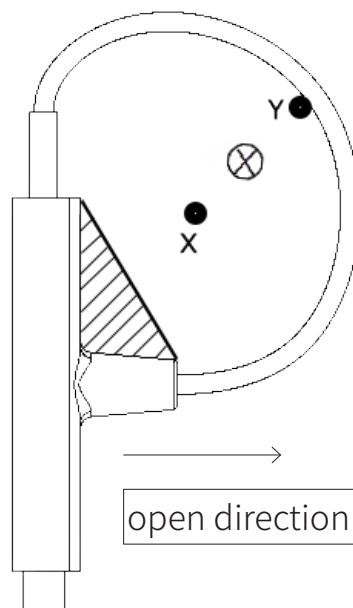

Technical Specifications

The technical specifications in the tables in this section are valid under the following conditions:

- * The probe has been calibrated at an ambient temperature of 23° C ±5° C.
- * The probe is connected to the host instrument using an input resistance of 1 MΩ.

Specifications for the Rogowski AC Current Probe are divided into three categories: Physical characteristics, Electrical characteristics, Environmental characteristics.

Physical Characteristics

Table 1: Mechanical Characteristics

Typical Characteristics describe typical performance.

The coil’s cross-sectional diameter, length, and lead length are all customizable.

Model	RCP-XS Series		RCP-S Series		RCP-M Series		RCP-L Series
Coil length (Typical)	80mm	200mm	200mm	700mm	200mm	700mm	700mm
Measurable conductor diameter	20mm	60mm	60mm	220mm	60mm	220mm	220mm
Coil cross-section diameter (Typical)	1.6mm		3.0 mm		4.5 mm		8.0mm
Accuracy (typical)	2%						
Power supply	DC 12V						
Integrator size	70*40*17mm						
Wire length (integrator to Rogowski coil)	1.5m (customizable)						
Output impedance	1MΩ						
Interface	Universal BNC						

Electrical Characteristics

Table 2: Typical Electrical Characteristics of the RCP-XS Series

Model	Bandwidth	Peak current	Output sensitivity	Output noise	Peak di/dt	Droop (%/ms)	Accuracy (typical)	Peak coil isolation voltage
RCP60XS-80	70Hz -30MHz	60Apk	100mV/A (10x)	< 25mVpp	4kA/μs	65%/ms	2%	1.5kVpk
RCP120XS-80	34Hz-30MHz	120Apk	50mV/A (20x)	< 25mVpp	8kA/μs	35%/ms		
RCP300XS-80	10Hz-30MHz	300Apk	20mV/A (50X)	< 25mVpp	20kA/μs	9%/ms		
RCP600XS-80	8Hz-30MHz	600Apk	10mV/A (100X)	< 18mVpp	40kA/μs	7%/ms		
RCP1200XS-80	5Hz-30MHz	1200Apk	5mV/A (200X)	< 15mVpp	70kA/μs	3%/ms		
RCP3000XS-80	4Hz-30MHz	3000Apk	2mV/A (500X)	< 8mVpp	70kA/μs	2%/ms		
RCP6000XS-80	4Hz-30MHz	6000Apk	1mV/A (1000X)	< 5mVpp	70kA/μs	2%/ms		
RCP12000XS-80	2Hz-30MHz	12000Apk	0.5mV/A (2000X)	< 6mVpp	70kA/μs	2%/ms		
RCP300XS-200	14Hz - 20MHz	300Apk	20mV/A (50X)	< 20mVpp	20kA/μs	15%/ms	2%	1.5kVpk
RCP600XS-200	7Hz - 20MHz	600Apk	10mV/A (100X)	< 18mVpp	40kA/μs	7%/ms		
RCP1200XS-200	5Hz - 20MHz	1200Apk	5mV/A (200X)	< 15mVpp	70kA/μs	3%/ms		
RCP6000XS-200	3Hz - 20MHz	6000Apk	1mV/A (1000X)	< 7mVpp	70kA/μs	3%/ms		

※ RCP***XS-80: 80 mm coil length.

※ RCP***XS-200: 200 mm coil length.

Table 3: Typical Electrical Characteristics of the RCP-S Series

Model	Bandwidth	Peak current	Output sensitivity	Output noise	Peak di/dt	Droop (%/ms)	Accuracy (typical)	Peak coil isolation voltage
RCP120S-200	14Hz - 25MHz	120Apk	50mV/A (20x)	< 25mVpp	8kA/μs	18%/ms	2%	3kVpk
RCP300S-200	7Hz - 25MHz	300Apk	20mV/A (50X)	< 20mVpp	20kA/μs	8%/ms		
RCP600S-200	5Hz - 25MHz	600Apk	10mV/A (100X)	< 18mVpp	40kA/μs	5%/ms		
RCP1200S-200	5Hz - 25MHz	1200Apk	5mV/A (200X)	< 7mVpp	70kA/μs	5%/ms		
RCP3000S-200	3Hz - 25MHz	3000Apk	2mV/A (500X)	< 7mVpp	70kA/μs	3%/ms		
RCP6000S-200	2Hz - 25MHz	6000Apk	1mV/A (1000X)	< 5mVpp	70kA/μs	2%/ms		
RCP6000S-700	3Hz-10MHz	6000Apk	1mV/A (1000X)	< 6mVpp	70kA/μs	3%/ms	2%	3kVpk
RCP12000S-700	2Hz-10MHz	12000Apk	0.5mV/A (2000X)	< 5mVpp	70kA/μs	2%/ms		

※ RCP***S-200: 200 mm coil length.

※ RCP***S-700: 700 mm coil length.

Table 4: Typical Electrical Characteristics of the RCP-M Series

Model	Bandwidth	Peak current	Output sensitivity	Output noise	Peak di/dt	Droop (%/ms)	Accuracy (typical)	Peak coil isolation voltage
RCP120M-200	14Hz - 25MHz	120Apk	50mV/A (20X)	< 25mVpp	8kA/μs	18%/ms	2%	5kVpk
RCP300M-200	7Hz - 25MHz	300Apk	20mV/A (50X)	< 20mVpp	20kA/μs	8%/ms		
RCP600M-200	5Hz - 25MHz	600Apk	10mV/A (100X)	< 18mVpp	40kA/μs	5%/ms		
RCP1200M-200	5Hz - 25MHz	1200Apk	5mV/A (200X)	< 7mVpp	70kA/μs	5%/ms		
RCP3000M-200	3Hz - 25MHz	3000Apk	2mV/A (500X)	< 7mVpp	70kA/μs	3%/ms		
RCP6000M-200	2Hz - 25MHz	6000Apk	1mV/A (1000X)	< 5mVpp	70kA/μs	2%/ms		
RCP6000M-700	3Hz-10MHz	6000Apk	1mV/A (1000X)	< 6mVpp	70kA/μs	3%/ms	2%	5kVpk
RCP12000M-700	2Hz-10MHz	12000Apk	0.5mV/A (2000X)	< 5mVpp	70kA/μs	2%/ms		

※ RCP***M-200: 200 mm coil length.
 ※ RCP***M-700: 700 mm coil length.

Table 5: Typical Electrical Characteristics of the RCP-L Series

Model	Bandwidth	Peak current	Output sensitivity	Output noise	Peak di/dt	Droop (%/ms)	Accuracy (typical)	Peak coil isolation voltage
RCP600L-700	8Hz-10MHz	600Apk	10mV/A (100X)	< 18mVpp	70kA/μs	8%/ms	2%	10kVpk
RCP1200L-700	6Hz - 10MHz	1200Apk	5mV/A (200X)	< 12mVpp	70kA/μs	5%/ms		
RCP3000L-700	4Hz - 10MHz	3000Apk	2mV/A (500X)	< 9mVpp	70kA/μs	2%/ms		
RCP6000L-700	3Hz - 10MHz	6000Apk	1mV/A (1000X)	< 6mVpp	70kA/μs	2%/ms		
RCP12000L-700	2Hz-10MHz	12000Apk	0.5mV/A (2000X)	< 5mVpp	70kA/μs	2%/ms		

※ RCP***L-700: 700 mm coil length.

Environmental Characteristics

Table 6: Environmental Characteristics

Characteristics	Parameters
Working temperature	Base unit: 0°C - 55°C Coil: -20°C - 125°C
Storage temperature	-30°C -70°C
Working humidity	≤ 85%RH
Storage humidity	≤ 90%RH
Working height	≤ 3000m
Storage height	≤ 12000m

Precautions

This section includes common problems need attention during the use of the probe.

- * Ensure that the oscilloscope input impedance is set to 1 M Ω rather than 50 Ω ; otherwise, accurate measurements cannot be obtained.
- * The measured current must not exceed the probe's maximum rated current.
- * Before connecting to the circuit under test, avoid sharp spikes or edges, as they may damage the probe loop.
- * When measuring signals, keep the probe as far as possible from fast-changing high-voltage interference sources (e.g., signals above 100 V/ μ s) or high-frequency interference (MHz range or higher) to prevent measurement errors.
- * Strong magnetic fields (e.g., near transformers or high-current conductors) or strong electromagnetic fields (e.g., near radio transmitters) can affect measurement results.
- * At high frequencies, common-mode noise may affect measurements on the high-voltage side of the circuit; in such cases, connect the probe to the low-voltage side or reduce the signal frequency.
- * To detect strong nearby interference sources, place the probe loop around the conductor without clamping it and measure the ambient interference signal strength.
- * Avoid excessive bending, stretching, or twisting of the probe loop during use to prevent damage to the internal coil.
- * Before measurement, ensure that the Rogowski coil is fully closed and securely connected; incomplete closure may result in measurement errors or reduced sensitivity.

Maintenance

This section provides maintenance information for the probe.

Troubleshooting

If some function of the probe is not working properly, there may be an error. See the table below.

Table 7: Probe Troubleshooting

Malfunctions	Possible Cause
Excessive waveform jitter or noise	<p>The measured waveform shows excessive jitter or noise.</p> <p>Check for strong magnetic or electromagnetic interference near the probe.</p> <p>The probe loop is not properly secured and may have shifted position.</p> <p>The signal frequency may be too high and exceed the probe's effective bandwidth.</p>
Inaccurate measurement results	<p>Check whether the oscilloscope input impedance is set to 1 MΩ.</p>
Zero offset in the measured value	<p>Large changes in ambient temperature may cause probe zero drift.</p> <p>The probe may not have reached a stable operating state after a long period of inactivity.</p> <p>External magnetic field interference may be present near the probe.</p>
The probe cannot measure the signal.	<p>The oscilloscope channel may be damaged, please try to replace other channels or other oscilloscopes. if the probe works normally on other channels or oscilloscopes, it is considered to be caused by the oscilloscope channel and has nothing to do with the probe; If the probe does not work on other channels or on the oscilloscope, the probe may be defective, please contact the Micsig after-sales department for repair.</p>

Cleaning

Do not expose the probe to harsh weather conditions, the probe is not waterproof.

⚠ CAUTION: To prevent damage to the probe, do not expose it to sprays, liquids or solvents. When cleaning the outside of the probe, avoid wetting the inside, the probe is not waterproof.

Do not wipe the probe with chemical cleaners, they may damage the probe. Avoid chemicals containing gasoline, benzene, toluene, xylene, acetone, or similar solvents.

Clean the outside of the probe with a soft, dry, lint-free cloth or a soft bristle brush. If dirt remains, clean with a soft cloth or cotton swab dipped in 75% isopropyl alcohol solution and rinse with deionized water. Cotton swabs can be used to clean the tight spaces of the probe with any solution that can dampen the swab or soft cloth.

Do not use abrasives on any part of the probe.



Micsig Shenzhen Micsig Technology Co., Ltd.

Tel: +86-(0)755-88600880 Email: sales@micsig.com Website: www.micsig.com

Add: 6F, Jinhuan Building, No. 56, Tiezai Rd, Bao'an District, Shenzhen, Guangdong, China.