

Quick Guide

High Voltage Differential Probe DP series

1. Overview

Micsig DP Series High-Voltage Differential Probe offers a bandwidth of 100-300 MHz and a maximum input voltage of 7000 Vpk. With a standard BNC interface, they are compatible with oscilloscopes of most brands.

Features include one-button calibration, overload alarm, range power-off memory, dual voltage ranges, and a high-resistance, low-capacitance design to minimize loading. The probe delivers strong amplitude-frequency performance, and a high common-mode rejection ratio.

Command-based programming enables automated testing. 5 MHz bandwidth-limit function helps suppress high-frequency noise, delivering clearer waveforms.



2. Characteristics

Model	DP700	DP702	DP1500	DP1502	DP1503	DP3000	DP3002	DP3003	DP7000	DP7002
Bandwidth	100MHz	200MHz	100MHz	200MHz	300MHz	100MHz	200MHz	300MHz	100MHz	200MHz
Attenuation	20X / 200X		50X / 500X			100X / 1000X			100X / 1000X	
Max. input Differential Voltage (DC+AC PK)	70V (20X) 700V (200X)		150V (50X) 1500V (500X)			300V (100X) 3000V (1000X)			700V (100X) 7000V (1000X)	
Max. Voltage to ground	CAT I 600V CAT II 450V		CAT II 1000V CAT III 600V			CAT II 1000V CAT III 600V			CAT II 1500V CAT III 1000V	
Max. Common Mode Voltage	700V		1500V			3000V			7000V	
CMRR	DC : >80dB 100kHz: >60dB 10MHz: >30dB 100MHz: >26dB		DC : >80dB 100kHz: >60dB 10MHz: >30dB 100MHz: >26dB			DC : >80dB 100kHz: >60dB 10MHz: >30dB 100MHz: >26dB			DC : >80dB 100kHz: >60dB 10MHz: >30dB 100MHz: >26dB	
Output voltage	≤ 3.5V		≤ 3V			≤ 3V			≤ 7V	
Accuracy	±2% (Customizable 1% accuracy)									
Output impedance	100 MHz/ 200 MHzbandwidth probe: 1 MΩ 300 MHz bandwidth probes: 50 Ω									
Power supply	DC 5V									
Overrange	LED flashes, Buzzer beeps									
Dimensions	L*W*H: 13.5 *5*2.5 /cm									
Cable length	Approx. 31 cm (Input); Approx. 100cm (Output)									
Temperature	Operating: 0°C ~ 40 °C Non-operating: -30 °C ~ 70 °C									
Humidity	Operating: 5 ~ 85% RH (0°C ~ 40 °C) Non-operating: 5% ~ 85% RH (≤ 40 °C) ; 5% ~ 45% RH (40 °C ~70 °C)									
LVD standard	EN 61010-1:2010; EN IEC 61010-2-030:2021; EN 61010-031:2015+A1:2021+A11:2021									
EMC standard	EN IEC 61326-1:2021; EN IEC 61326-2-1:2021; EN61000-3-2:2019+A1:2021; EN61000-3-3:2013+A1:2019+A2:2021									

- Other models are customizable. For more details, please contact us.

3. Appearance

The main body of the DP series high-voltage differential probe (intergrated version) is as follows:

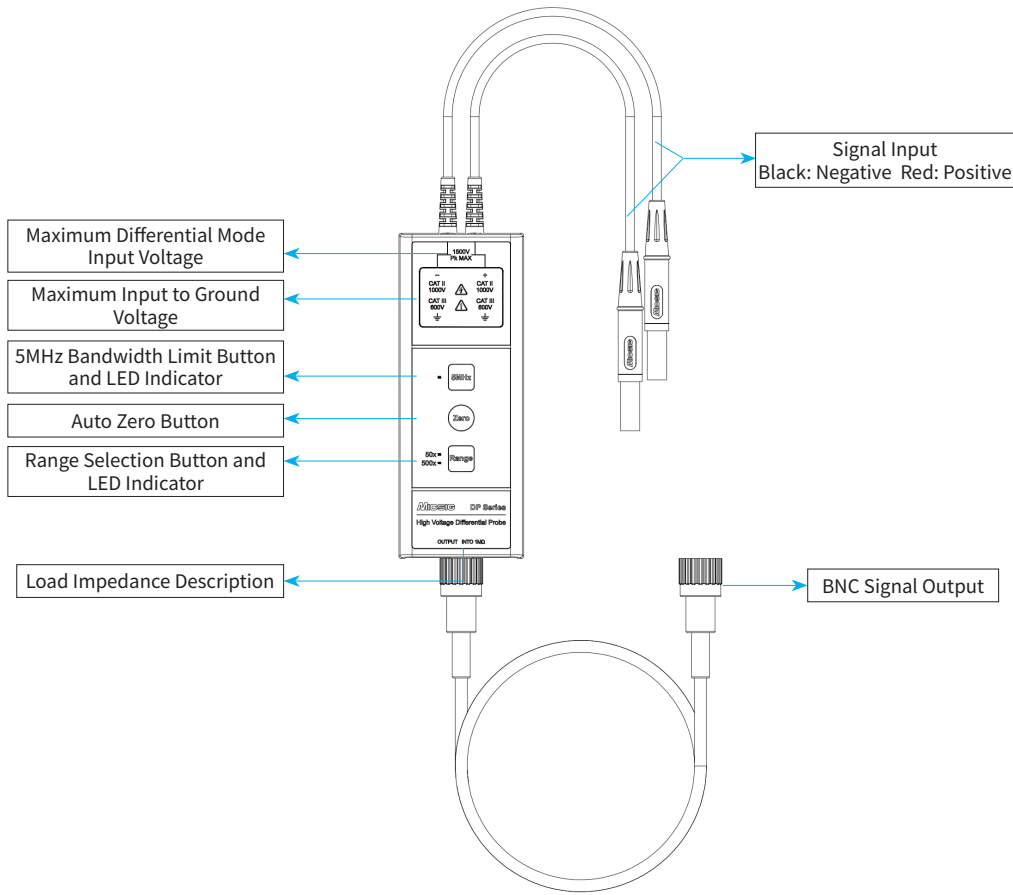

4. Precautions

- 1) The bandwidth of the oscilloscope should be no less than the bandwidth of the probe.
- 2) Calibrate the probe before use:
Short-circuit the input ends, power on, press “Zero” button, after hearing a “Di” sound, then calibration succeeds; Otherwise, if you hear “Di Di Di”, the calibration fails, then you need to calibrate again;
- 3) Recommend to use after 10 mins warm-up to get more accurate result.
- 4) When the range LED indicator flashes and beeps rapidly, it indicates Overvoltage warning, please switch the probe to higher range or stop testing.

5. Operation Steps

- 1) Power the probe: Power the probe with standard adapter;
- 2) Connect to oscilloscope: Connect the BNC end of the probe to oscilloscope channel (make sure the oscilloscope is grounded);
- 3) Select Range: Select appropriate voltage range according to the signal;
- 4) Connect the DUT: Use clips or hooks to connect the DUT. For reducing interference, twist the red and black input leads into a pair prior. If an over-voltage alarm occurs, disconnect the power supply and the circuit immediately;
- 5) Set on the oscilloscope: Set the oscilloscope input impedance. Adjust the channel attenuation ratio.

*Note: Try not to use extension leads when measuring, it could bring more noise. If must use the extension leads, please twist the leads together to reduce noise, and the input frequency should not exceed 5MHz, if not, the test result may not be accurate.

6. Warranty

- 1) Micsig warrants the main body of this differential probe for 1 year. During the warranty period, Micsig will be responsible for free maintenance for any failure caused by the quality of the product under normal use.
- 2) Under the following circumstances, Micsig will refuse to provide maintenance services or charge a fee:
 - a. No packaging or anti-counterfeiting label.
 - b. Anti-counterfeit label has been altered or blurred beyond recognition.
 - c. Unauthorized disassembly, such as: changing wires, dismantling internal components, etc.
 - d. No sales voucher or the content of sales voucher does not match the product.

7. Safety Precautions

- 1) Non-professionals do not open the product casing;
- 2) Do not use while case is open;
- 3) Do not touch any bare metal while testing;
- 4) Disconnect the power supply and circuit immediately when over range;
- 5) Do not use in flammable and explosive environments;



MICSIG Shenzhen Micsig Technology Co., Ltd.

Tel: +86-(0)755-88600880 Email: sales@micsig.com Website: www.micsig.com

Add: 6F, Jinhuan Building, No. 56, Tiezai Rd, Bao'an District, Shenzhen, Guangdong, China.

*The final interpretation of this content is vested in Shenzhen Micsig Technologies Co., Ltd. For any updates to relevant information, please follow the official Micsig website (www.micsig.com).